

QuickWood

Automatic Machines for Finishing and Sealer Sanding

Model Elite 1400

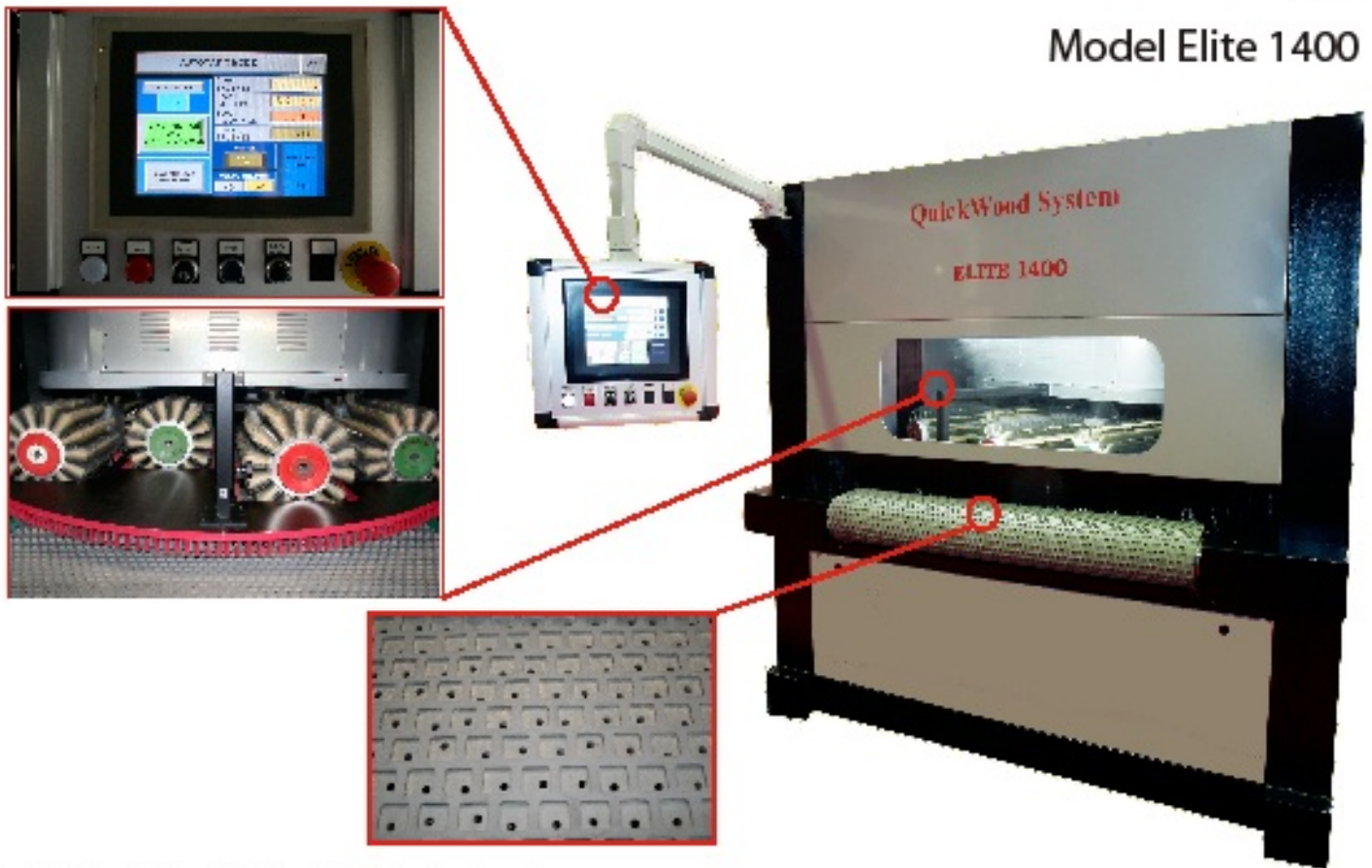

QuickWood Model Elite 1400 Series Sander

The Elite 1400 is designed for Finishing and Sealer Sanding/ de-nibbing of three dimensional work pieces, items with profiles, raised panel and flat doors, drawer fronts and moldings, hardwood and MDF.

The machine has a carousel with 4 gear heads with 2 spindles each, which counter rotate to each other. The 8 spindles are able to turn right and left depending on what sandpaper grit you want to use. The height of the spindles as well as the direction of the spindles are controlled from a 12" touch screen control panel. The control panel has the ability to store 99 automatic sanding programs for spindle speed, carousel speed, conveyor speed and sanding height for easy transition between sanding jobs.

The Elite 1400 has a 55" wide belt making this machine the largest 8 spindle Elite series sander.

Alternatively you can choose between a standard belt and a vacuum belt with a very strong capacity of vacuum. The vacuum pump is integrated in the machine and does not need any silencer. The Elite series sander has the option to add a 40/60 split belt vacuum system for stronger hold of smaller parts.



Technical Specifications

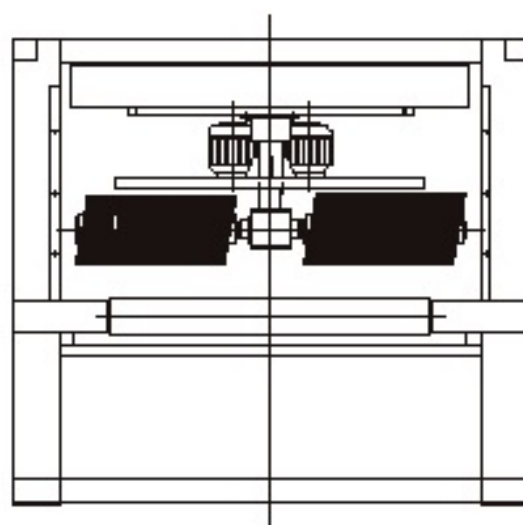
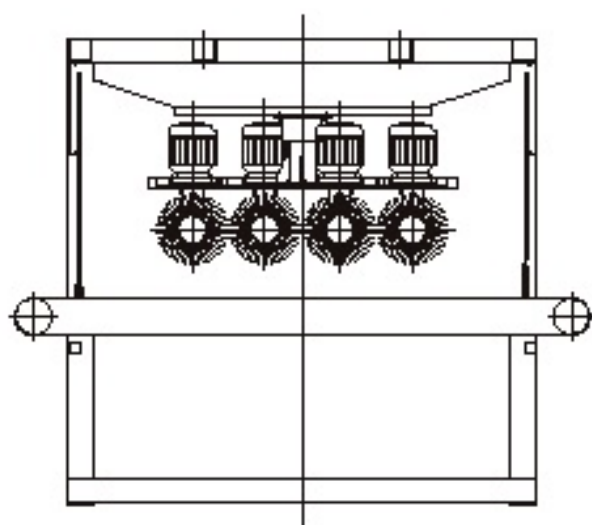

Model Elite	1100	1400
Dimension of workpiece:		
Height max., mm	100	100
Width max., mm	1100	1400
Length	infinite	infinite
Troughfeed width, m/min.	2-12	2-12
Spindle speed, RPM	300-1150	300-1150
Rotation speed, RPM	3-16	3-16
Spindle length, mm	390	540
Number of spindles	8	8
Diameter of tool max., mm	350	350
Total number of QUICK-Discs/QN	256/120	344/168
Main motor, kW	4 x 1.5	4 x 1.84
Frequency alternator spindles, kW	7.5	11
Conveyor motor, kW	1.1	1.5
Rotation motor, kW	1.1	1.5
Vacuum pump, kW	11	2 x 7.5
Height adjustment, kW	0.45	0.45
Dust collection duct, mm	4 x 140	6 x 140
Exhaust capacity, m ³ /h	5600	8000
Net weight, kg	Appr. 1800	Appr. 2100

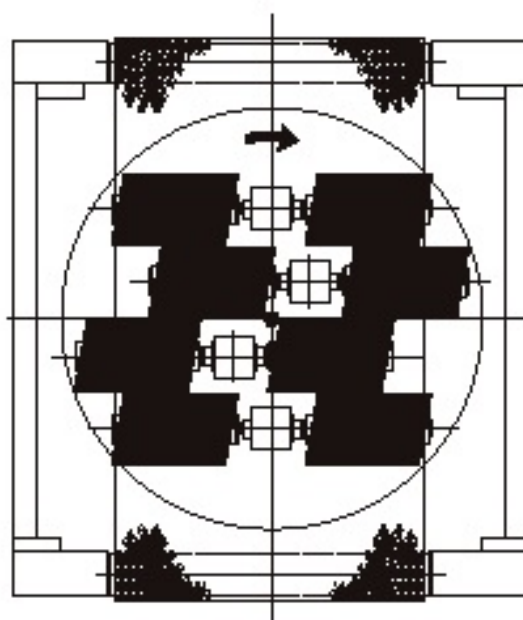

Dimensions (WxLxH)

PRO-1100	2020 x 2410 x 2050 mm
PRO-1400	2240 x 2630 x 2050 mm

QuickWood

Sand-Tech Inc
805 Marathon Pkwy. Suite 110
Lawrenceville, GA 30045

Phone:(770) 682-8863 • Fax:(770) 682-3960
email: quickwood@msn.com • Homepage: www.quickwood.com

